

HSF

- NOTES:
- 1.Current Rating: 0.3A ;
 - 2.Voltage Rating: 30V AC ;
 - 3.Contact Resistance: 90mΩ Max;
 - 4.Withstand Voltage: 100V AC;
 - 5.Insulation Resistance: 50MΩ Min;
 - 6.Operating Temperature: -40°C to +105°C;
 - 7.Insulator Material: LCP,G.F,UL94V-0,BK;
 - 8.Contact Material: Copper Alloy;
 - 9.Contact plating:

xxμ" Gold on contact area (See ordering information),
50μ" Nickel underplating overall;

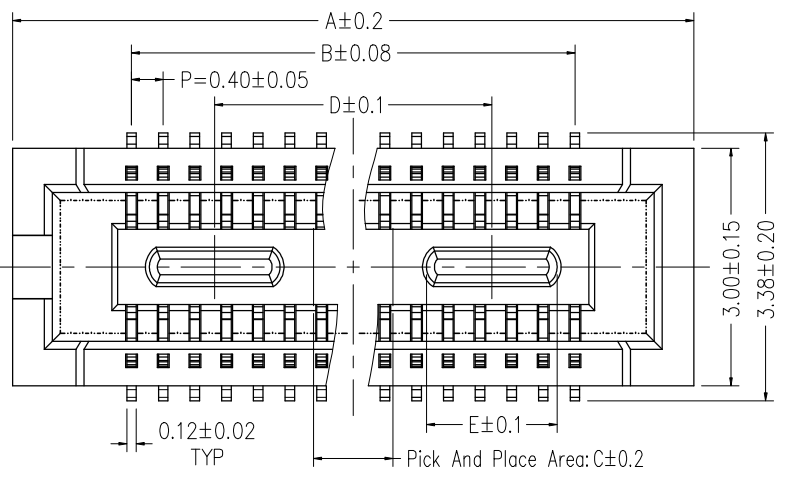

PART NO.	NO.of contacts	A	B	C	D	E
3630-S020-014G1R01	20	6.60	3.60	1.0	2.45	1.05
3630-S024-014G1R01	24	7.40	4.40	1.0	2.55	1.05
3630-S030-014G1R01	30	8.60	5.60	1.5	3.50	1.65
3630-S034-014G1R01	34	9.40	6.40	2.3	4.30	1.65
3630-S040-014G1R01	40	10.60	7.60	3.2	5.25	1.65
3630-S050-014G1R01	50	12.60	9.60	3.2	5.45	1.65
3630-S060-014G1R01	60	14.60	11.60	3.2	5.45	1.65
3630-S070-014G1R01	70	16.60	13.60	3.2	6.95	1.65
3630-S080-014G1R01	80	18.60	15.60	3.2	8.95	1.65
3630-S090-014G1R01	90	20.60	17.60	3.2	8.95	1.65
3630-S100-014G1R01	100	22.60	19.60	3.2	9.95	1.65

Ordering Information

3630 - S XXX - 014 G1 R 01

- S=Socket
- No.of Pins:
020=20Pin; 024=24Pin;
030=30Pin; 034=34Pin;
040=40Pin; 050=50Pin;
060=60Pin; 070=70Pin;
080=80Pin; 090=90Pin;
100=100Pin
- Socket High:
014=1.45mm
- Contact plating:
G1=3μ"Gold
- Packing:R=Tape & Reel
- WCON internal code

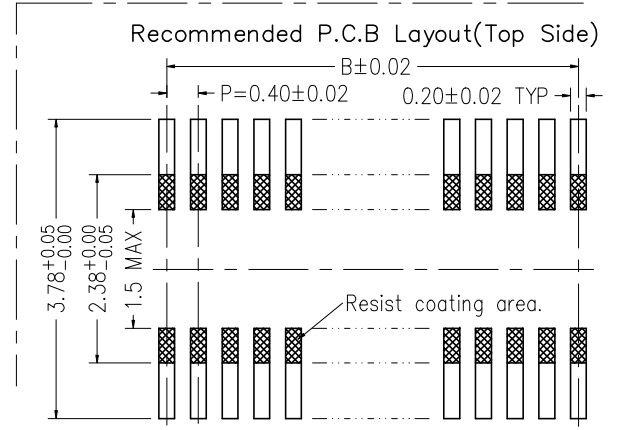
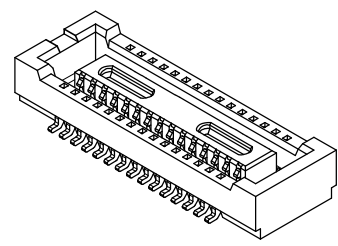
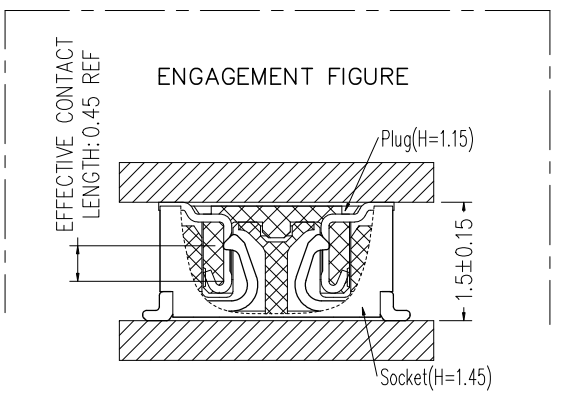
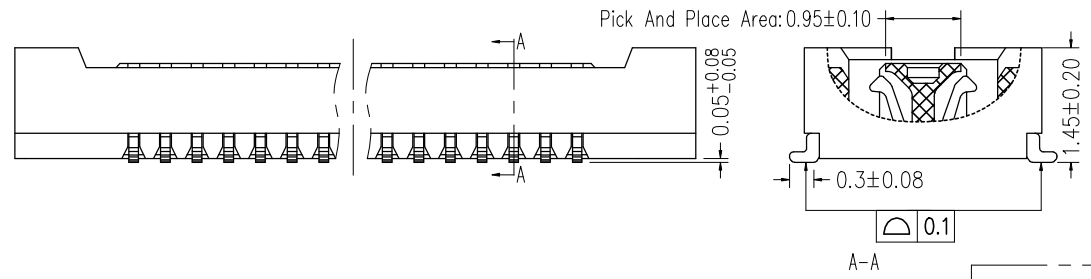

REV	DATE	MODIFICATION DESCRIPTION	CHANGE	OPERATION	DRAW	DATE	SCALE	FIT	PART NO.
A2	2022.02.23	Changes Operating Temperature	OHJ	x.x ±0.40	OHJ	2022.02.23	UNIT	mm	RH-3630-SXXX-014GXR01
A1	2021.10.20	Appearance changes based on the product requiremeng	OHJ	x.xx ±0.25	CHECK	DATE	SIZE	A4	TITLE: 0.4mm B TO B SOCKET(H=1.45)
A0	2019.05.13	NEW	LEVI-LIU	x.xxx ±0.15	APPROVE	DATE	SHEET	1/1	180° SMT TYPE Without Reinforcing Metal Fitting
				Angle ± 3°			PROJ.		Customer NO.
				DIM TOL					

仁昊伟业
RENHOTEC

<https://www.renhotec.com>

info@renhotec.com