

# HSF

- NOTES:
- Current Rating: 0.3A ;
  - Voltage Rating: 30V AC ;
  - Contact Resistance: 90mΩ Max;
  - Withstand Voltage: 100V AC;
  - Insulation Resistance: 50MΩ Min;
  - Operating Temperature: -40°C to +105°C;
  - Insulator Material: LCP,G.F,UL94V-0,BK;
  - Contact Material: Copper Alloy;
  - Contact plating:
  - 3μ" Gold on contact area,
  - 50μ" Nickel underplating overall;
  - Recommended process:
  - IR soldering,Peak temperature:260±5°C, 5s ;

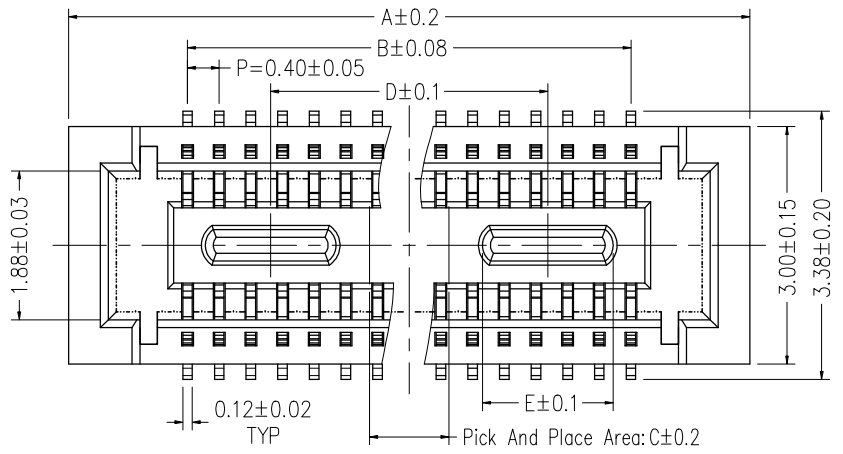

PART NO.	NO.of contacts	A	B	C	D	E
3630-S020-024G1R01	20	6.60	3.60	1.0	2.45	1.05
3630-S040-024G1R01	40	10.60	7.60	3.2	5.25	1.65
3630-S050-024G1R01	50	12.60	9.60	3.2	5.45	1.65
3630-S060-024G1R01	60	14.60	11.60	3.2	5.45	1.65
3630-S070-024G1R01	70	16.60	13.60	3.2	6.95	1.65

## Ordering Information

3630 - S XXX - 024 G1 R 01

- S=Socket
- No. of Pins: 020=20Pin; 040=40Pin; 050=50Pin; 060=60Pin; 070=70Pin
- Socket High: 024=2.4mm
- Contact plating: G1=3μ" Gold
- Packing: R=Tape & Reel
- WCON internal code

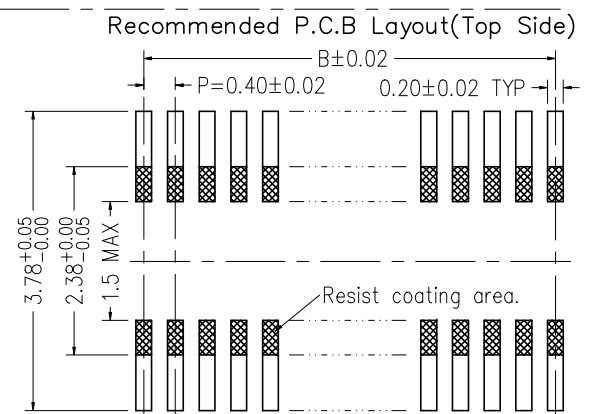
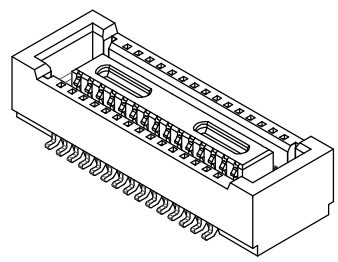
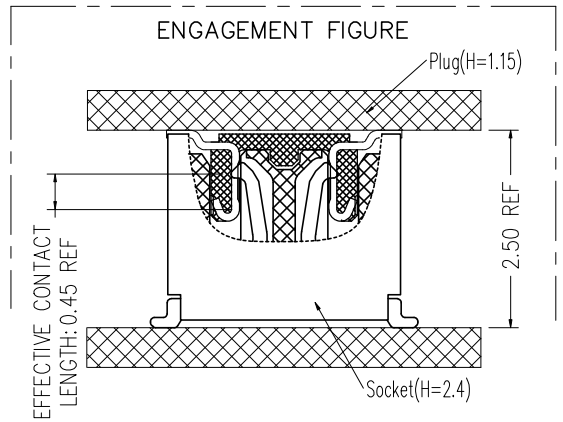
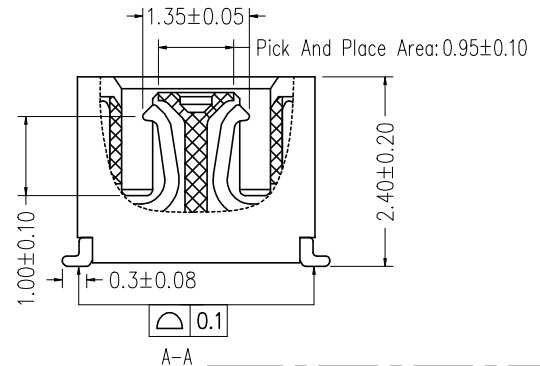
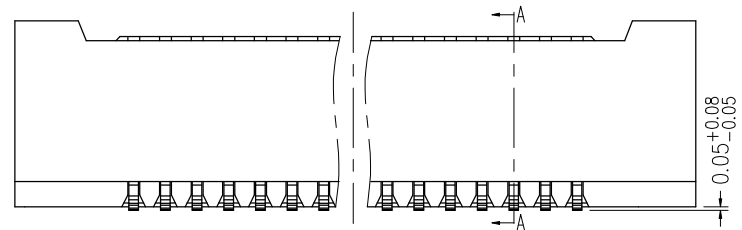

REV	DATE	MODIFICATION DESCRIPTION	CHANGE	OPERATION	DRAW	DATE	SCALE	FIT	PART NO.
A2	2022.02.23	Changes Operating Temperature, Add 70Pins specifications	OHJ	X.X ±0.40	OHJ	2022.02.23	UNIT	mm	RH-3630-SXXX-024XXR01
A1	2021.08.03	Reduce plastic	OHJ	X.XX ±0.25	CHECK	DATE	SIZE	A4	TITLE: 0.4mm B TO B SOCKET(H=2.4)
A0	2019.05.13	NEW	LEVI-LIU	X.XXX ±0.15	APPROVE	DATE	SHEET	1/1	180° SMT TYPE Without Reinforcing
				Angle ± 3°			PROJ.		Customer NO.
				DIM TOL					



<https://www.renhotec.com>

info@renhotec.com