

# HSF

- NOTES:
- 1.Current Rating:0.3A ;
  - 2.Voltage Rating:30V AC ;
  - 3.Contact Resistance: 90mΩ Max;
  - 4.Withstand Voltage: 100V AC;
  - 5.Insulation Resistance: 50MΩ Min;
  - 6.Operating Temperature: -40°C to +105°C;
  - 7.Insulator Material: LCP,G.F,UL94V-0,BK;
  - 8.Contact Material: Copper Alloy;
  - 9.Contact plating:  
3μ" Gold on contact area,  
50μ" Nickel underplating overall;
  - 10.Recommended process:  
IR soldering,Peak temperature:260±5°C, 5s ;

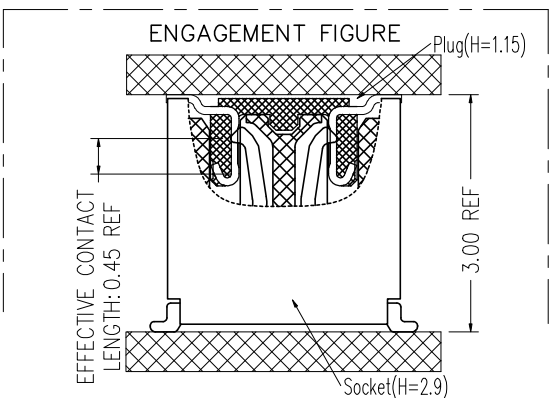
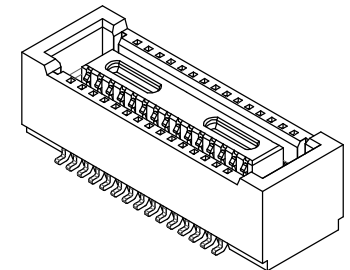
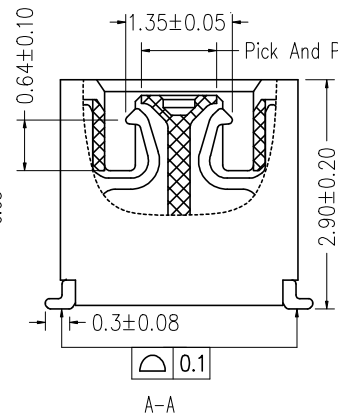
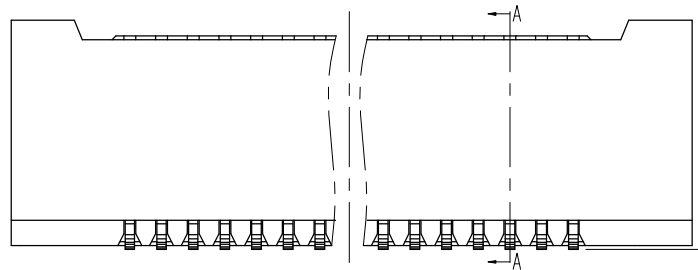
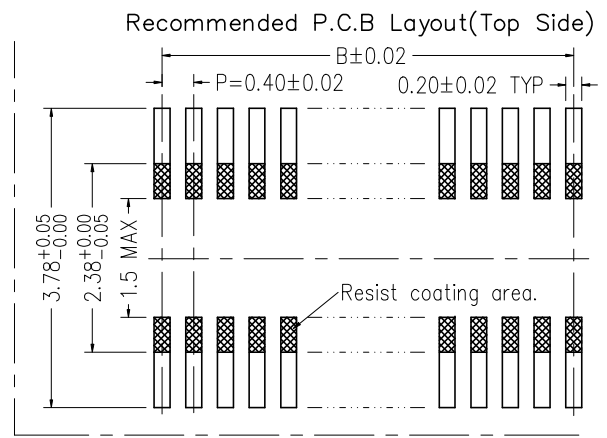
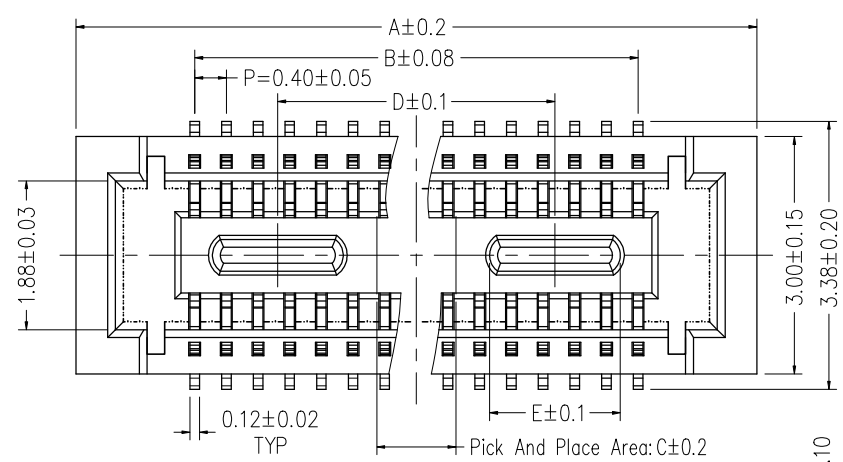

## Ordering Information

3630 - S XXX - 029 G1 R 01

- S=Socket
- No.of Pins:  
030=30Pin; 040=40Pin;  
044=44Pin; 050=50Pin;  
060=60Pin; 070=70Pin;  
080=80Pin; 090=90Pin;  
100=100Pin;
- Socket High:  
029=2.9mm
- Contact plating:  
G1=3μ"Gold
- Packing:R=Tape & Reel
- WCON internal code

PART NO.	NO.of contacts	A	B	C	D	E
3630-S030-029G1R01	30	8.60	5.60	1.5	3.50	1.65
3630-S040-029G1R01	40	10.60	7.60	3.2	5.25	1.65
3630-S044-029G1R01	44	11.40	8.40	3.2	5.25	1.65
3630-S050-029G1R01	50	12.60	9.60	3.2	5.45	1.65
3630-S060-029G1R01	60	14.60	11.60	3.2	5.45	1.65
3630-S070-029G1R01	70	16.60	13.60	3.2	6.95	1.65
3630-S080-029G1R01	80	18.60	15.60	3.2	8.95	1.65
3630-S090-029G1R01	90	20.60	17.60	3.2	8.95	1.65
3630-S100-029G1R01	100	22.60	19.60	3.2	9.95	1.65

REV	DATE	MODIFICATION DESCRIPTION	CHANGE	OPERATION	DRAW OHJ	DATE	SCALE	FIT	PART NO.
A2	2022.02.21	Change Operating Temperature	OHJ	x.x ±0.40	OPERATION	2021.08.03	UNIT	mm	RH-3630-SXXX-029XXR01
A1	2021.08.03	Reduce plastic	OHJ	x.xx ±0.25	CHECK	DATE	SIZE	A4	TITLE: 0.4mm B TO B SOCKET(H=2.9)
A0	2019.05.13	NEW	LEVI-LIU	x.xxx ±0.15	APPROVE	DATE	SHEET	1/1	180° SMT TYPE Without Reinforcing
				Angle ± 3°			PROJ.		Customer NO.
				DIM TOL					



<https://www.renhotec.com>

[info@renhotec.com](mailto:info@renhotec.com)