

HSF PRELIMINARY

NOTE:
 Rated Current: 0.3A
 Rated Voltage: 60V AC/DC.
 Contact Resistance: 70mΩ Max
 Withstanding Voltage: 150V AC.
 Insulation Resistance: 1000MΩ Min(initial)
 Temperature Range: -55°C ~ +85°C
 IR soldering Peak Temperature: 260±5°C, 5S

Contact Material: Copper Alloy
 Contact Plating:
 xxu" Gold on contact area(See ordering information), 50u" Nickel underplating
 Overall
 Insulator Material: LCP, G.F, UL94 V-0, BK

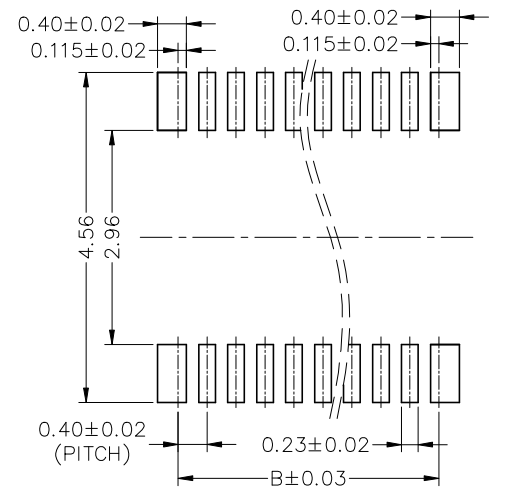
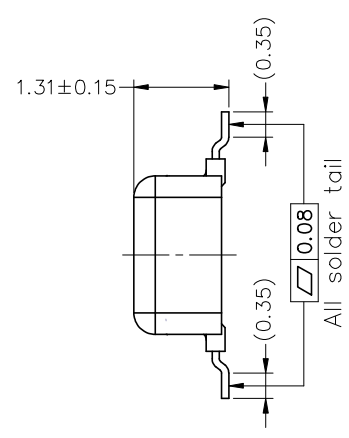
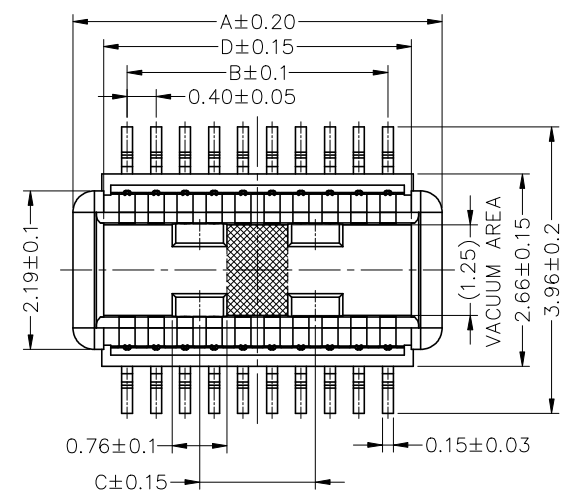

Recommended P.C.B Layout (Top Side)
 (PCB BOARD TOLERANCE ±0.05)

Ordering Information

3631- P XXX - 013 M XX R 01

P=Plug
 No. of pins
 020=20Pin; 024=24Pin;
 030=30Pin; 040=40Pin;
 050=50Pin; 060=60Pin;
 070=70Pin; 080=80Pin;
 100=100Pin

Plug High:
 013=1.31mm

M=SMT

Contact plating:
 G1=3u" GOLD
 G4=15u" GOLD

Packing:
 R=Tape & Reel

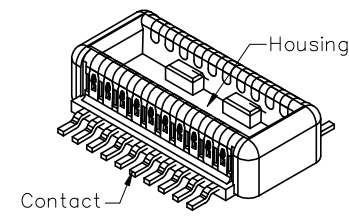
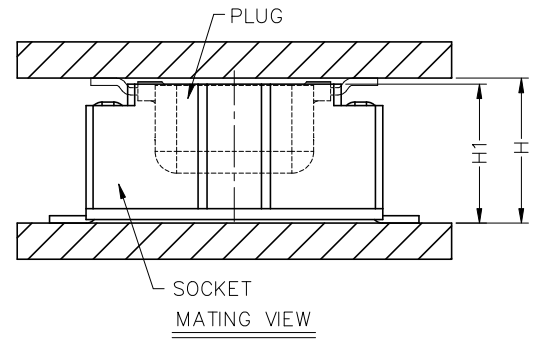
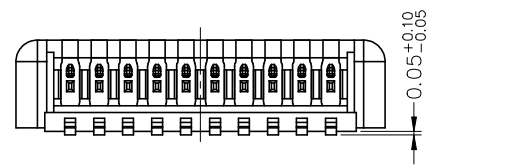

ASS'Y HIGH(H)	SOCKET(H1)
1.50	1.50
2.00	1.92
2.50	2.42

PIN	A	B	C	D
20	5.10	3.60	1.60	4.25
24	5.90	4.40	2.40	5.05
30	7.10	5.60	3.60	6.25
40	9.10	7.60	5.60	8.25
50	11.10	9.60	7.60	10.25
60	13.10	11.60	9.60	12.25
70	15.10	13.60	11.60	14.25
80	17.10	15.60	13.60	16.25
100	21.10	19.60	17.60	18.25

REV	DATE	MODIFICATION DESCRIPTION	CHANGE	OPERATION		DRAW	DATE	SCALE	FIT	PART NO.
				X.X	±0.40					
0	2022/12/21	NEW		X.XX	±0.25	XueLei	2022/12/21	UNIT	mm	RH-3631-PXXX-013MXXR01
				X.XXX	±0.15	CHECK	DATE	SIZE	A4	TITLE:
				Angle	± 3'	APPROVE	DATE	SHEET	1/1	0.40mm BTB, N Type, Male, SMT Type, H=1.31mm
				DIM	TOL			PROJ.	☞	Customer NO.



仁昊伟业
RENHOTEC

<https://www.renhotec.com>

info@renhotec.com