

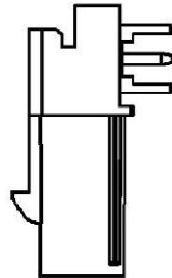

Product NO.		DOSIN-877-0110		
REV	DESCRIPTION	DWN	DATE	APPROVEN
A	First issue	Gavin	2019/09/12	John kine

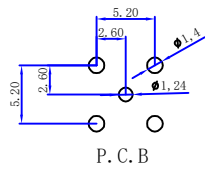
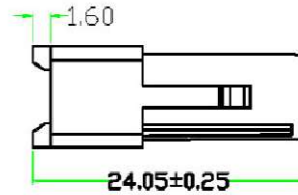
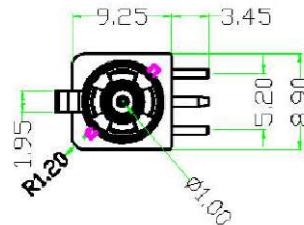
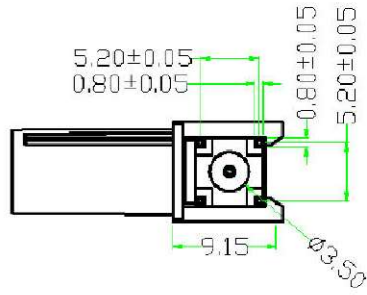
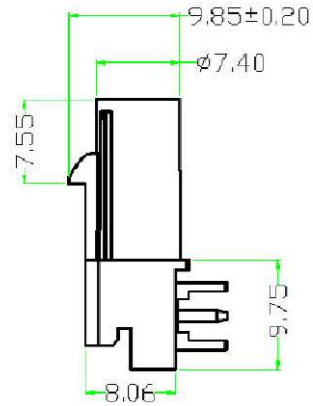

Coding	Graphics	Colour	Coding	Graphics	Colour
A		Jet Black	G		Blue Gray
B		White	H		Heather Violet
C		Signal Blue	I		Beige
D		Clart Violet	K		Curry
E		Leaf Green	L		Carmine Red
F		Nut Brown	M		Pastel Orange
Z		Water Blue	O		Pastel Green

NO	Description	Material	Finish	QTY
1	Shell	PBT		1
2	PIN	H65 BRASS	Gold	1
3	Body	Brass	Nickel	1
4	Insulator	PA66		1

NOTE:	Tolerance	X. ±0.20 X.X ±0.10 X.XX ±0.05 Angular ±5°	DOSIN Dosin Industrial (H.K) Co. Ltd 东莞市德索五金电子制品有限公司 Dosin Hardware Electronics Co., Ltd dosin2005@dosin-china.com Web: http://www.china-guan.com TEL: (0086) 769-81153906 FAX: (0086) 769-81875836
DRAWN Gavin	View		
CHECKED	UNIT	MM	Name: SMB PLUG Fakra Connector for PCB
APPROVALS John kine	SCALE	1:1	SIZE A Product NO. DOSIN-877-0110 REV A
		DateTime 2019/09/12	CAD FILE D/company drawings/BD SHEET: 1 OF 1